

LUMINET

Installation guide

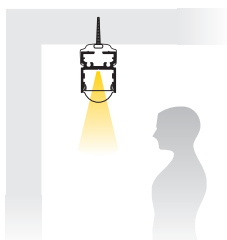

FIXED Installation



CEILING SUSPENSION Installation

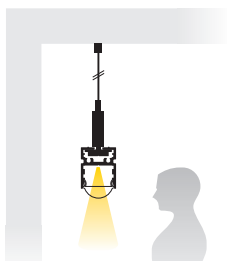

SURFACE ADJUSTABLE installation

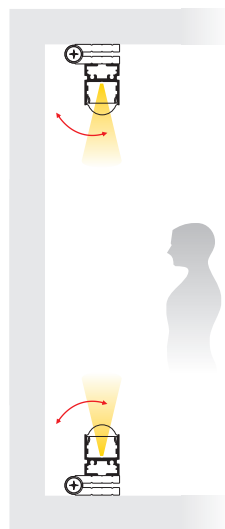

WALL BRACKET installation

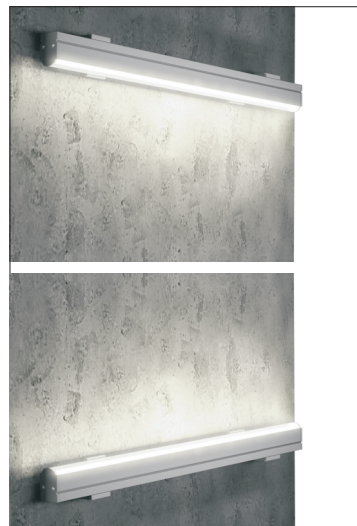
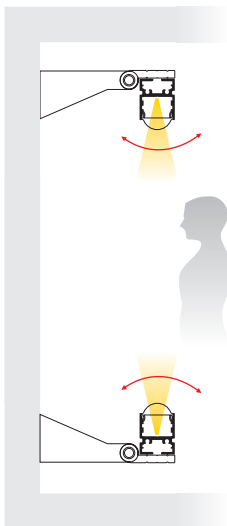

SURFACE ADJUSTABLE installation

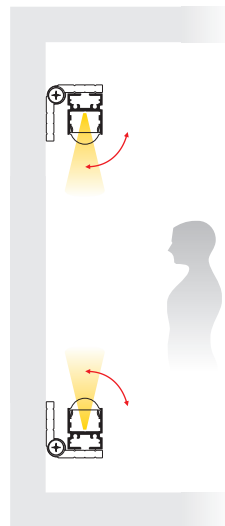

LUMINET

Assembly and installation guide

Select the position of the LED strip, using the sliding base profile for the desirable beam angle, as the illustration shows below.

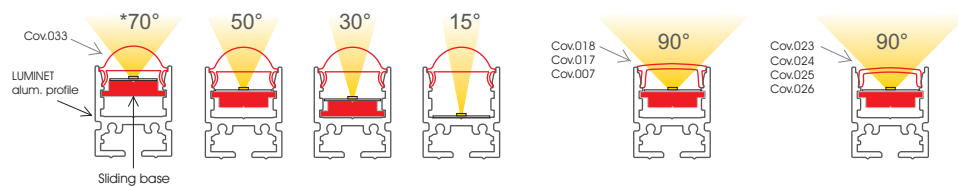

⚠ Attention: At 70° beam angle, the maximum fitting width of the LED strip is 10mm. For the others, is 12 mm.

Cut the LUMINET alum. profile in the desirable length. Then follow the steps below for each case.

1 Back exit of the cable

First, cut the sliding base 8mm shorter, than the LUMINET alum. profile.

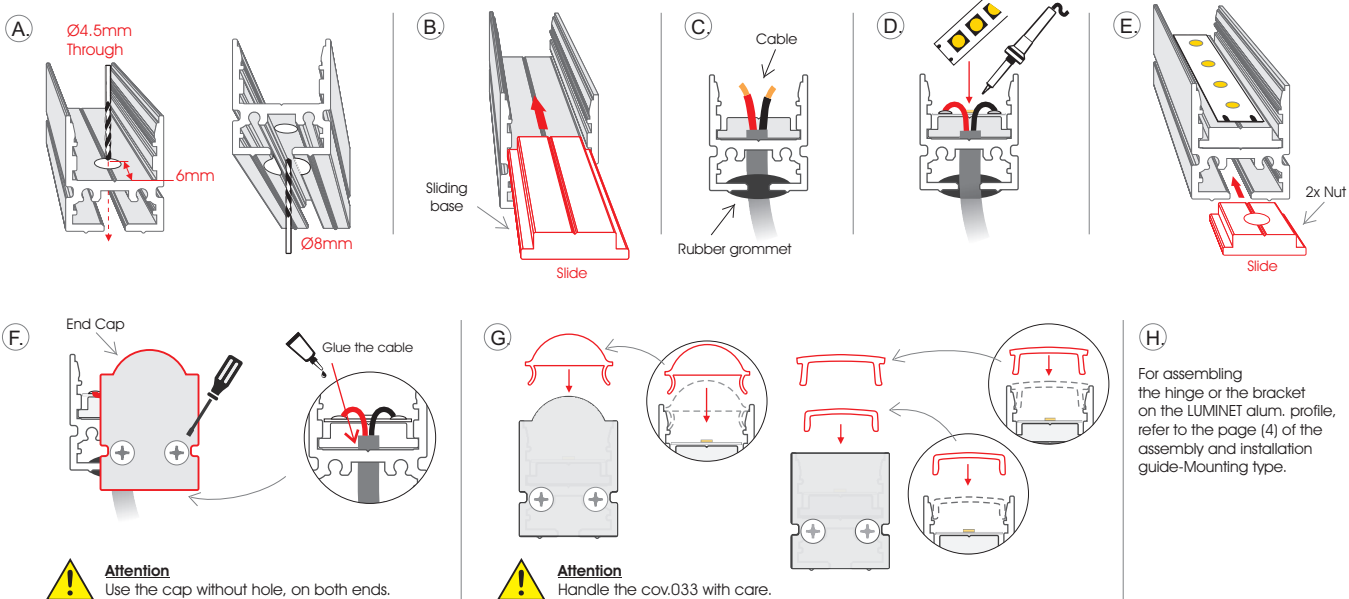

2 Side exit of the cable

First, cut the sliding base 8mm shorter, than the LUMINET alum. profile.

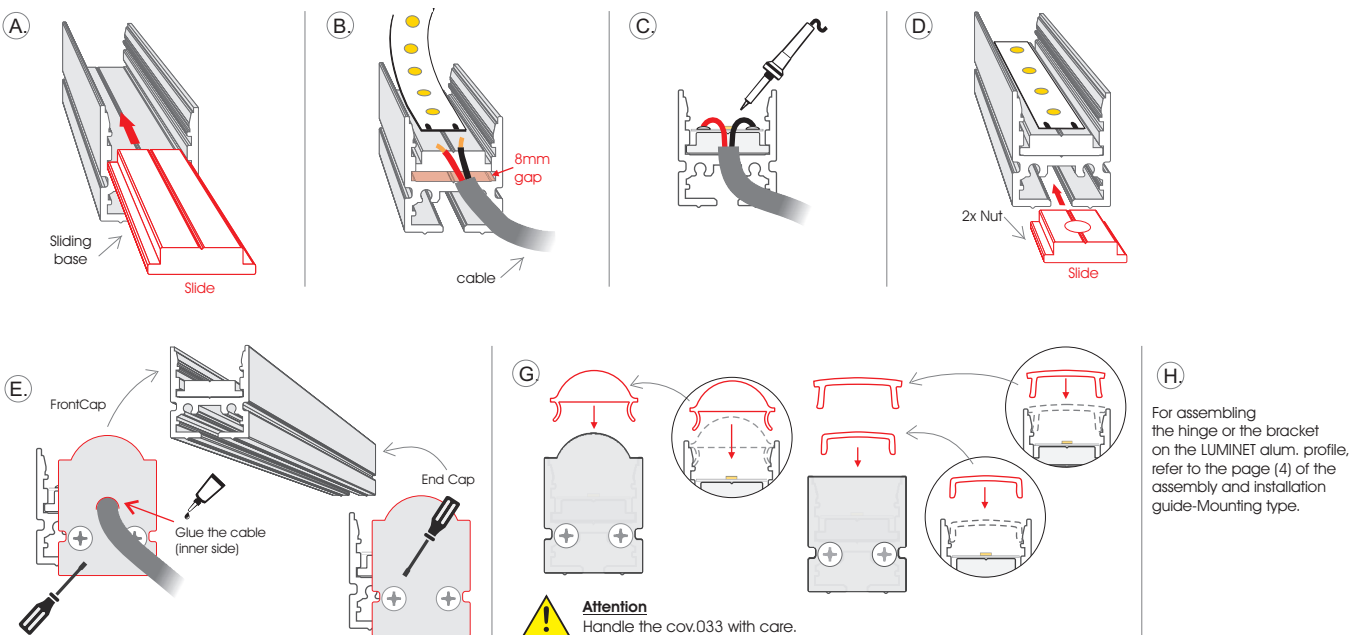

LUMINET

Assembly and installation guide

3 Pendant case

First, cut the sliding base 8mm shorter, than the LUMINET alum. profile.

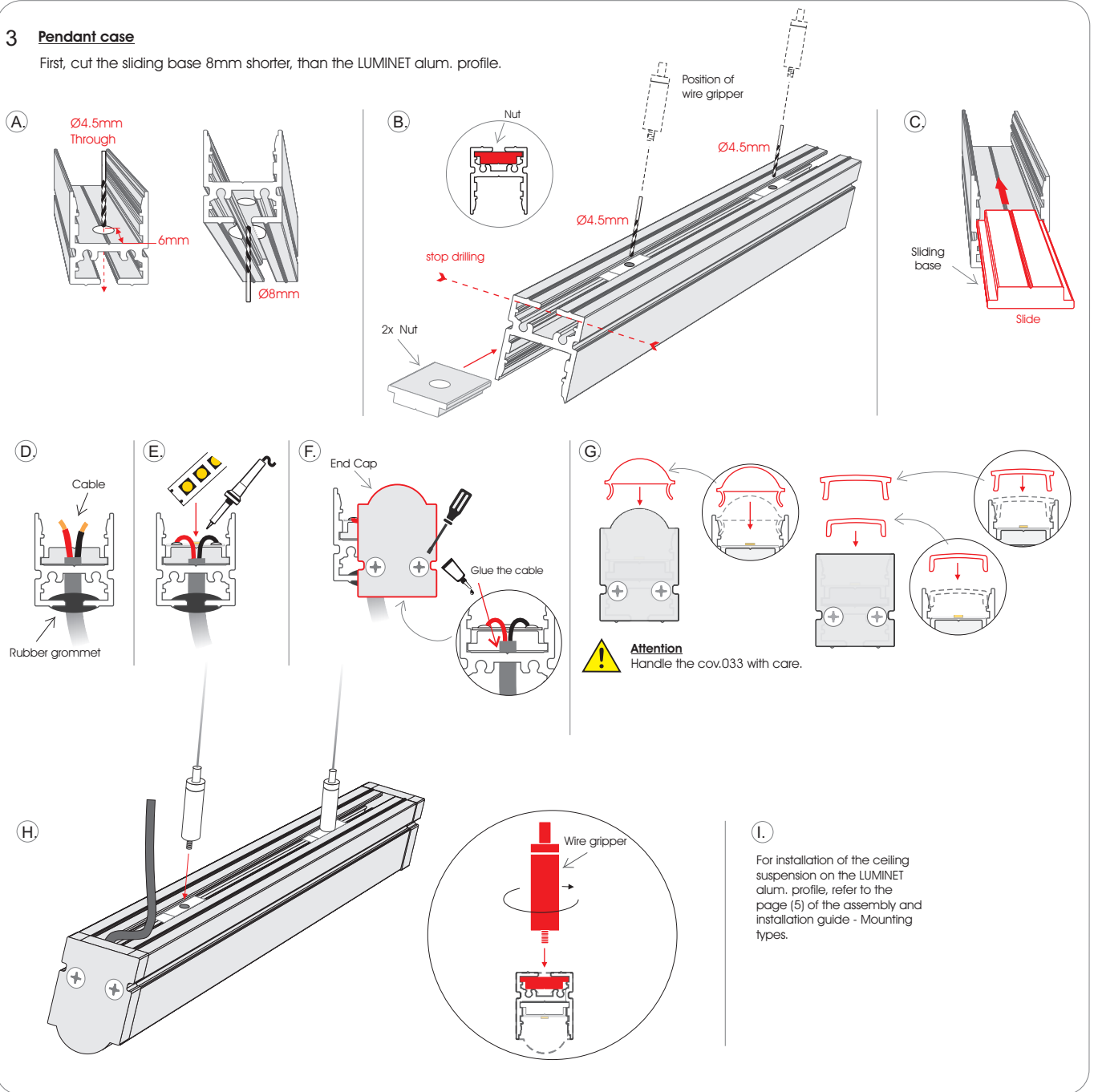

Note: To join a profile with another, use the extension line accessory, as the illustration shows.

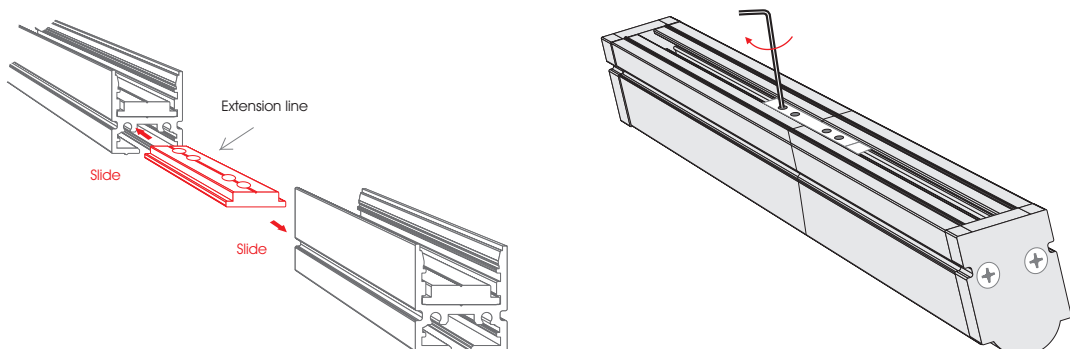

LUMINET

Assembly and installation guide Mounting types

Select the mounting type of the luminaire, according to the illustration below and follow the steps for each type.

SURFACE A ADJUSTABLE installation

ACC.280 - 2pcs/2m

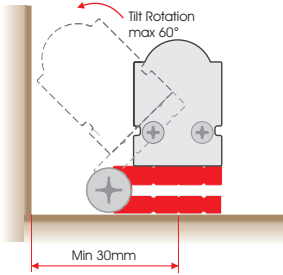

SURFACE B ADJUSTABLE installation

ACC.280 - 2pcs/2m

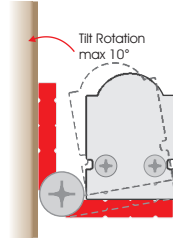

FIXED installation

PRH.001 - 2pcs/m

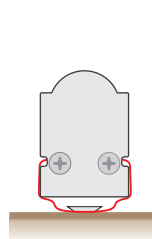

WALL BRACKET installation

ACC.282/281 - 1set/2m

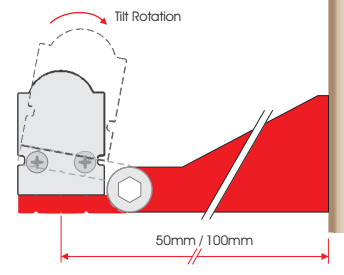

CEILING SUSPENSION installation

ACC.106 - 1set/2m

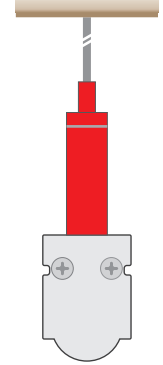

SURFACE A ADJUSTABLE assembly and installation

Mounting on Ground and Ceiling

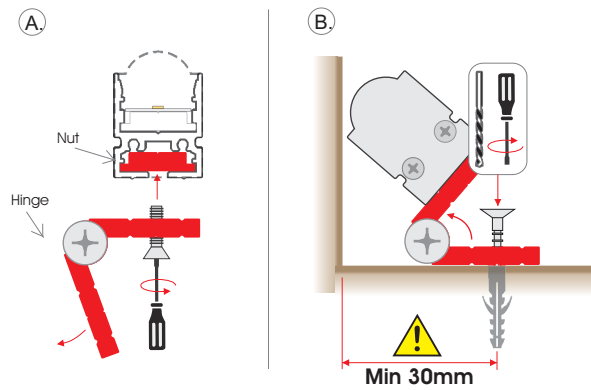

SURFACE B ADJUSTABLE assembly and installation

Mounting on Wall

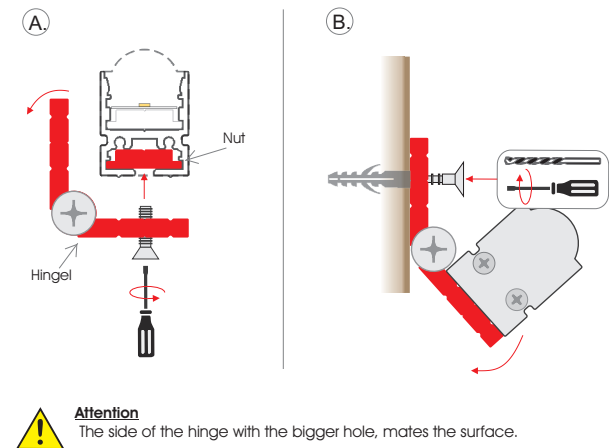

FIXED installation



LUMINET

Assembly and installation guide Mounting types

WALL BRACKET assembly and installation

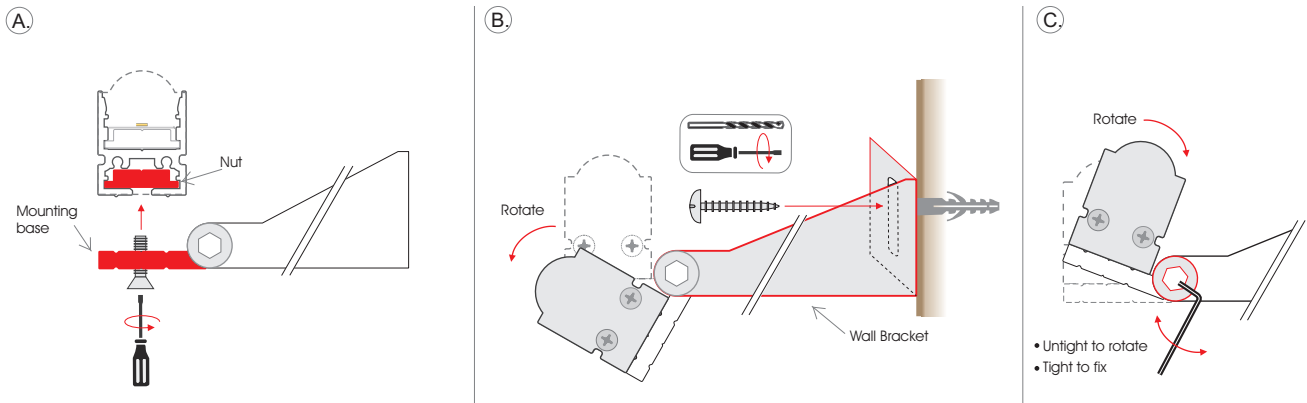

CEILING SUSPENSION installation

Mount the ceiling attachment of the hanging kit on the ceiling, in a way that the illustration shows.

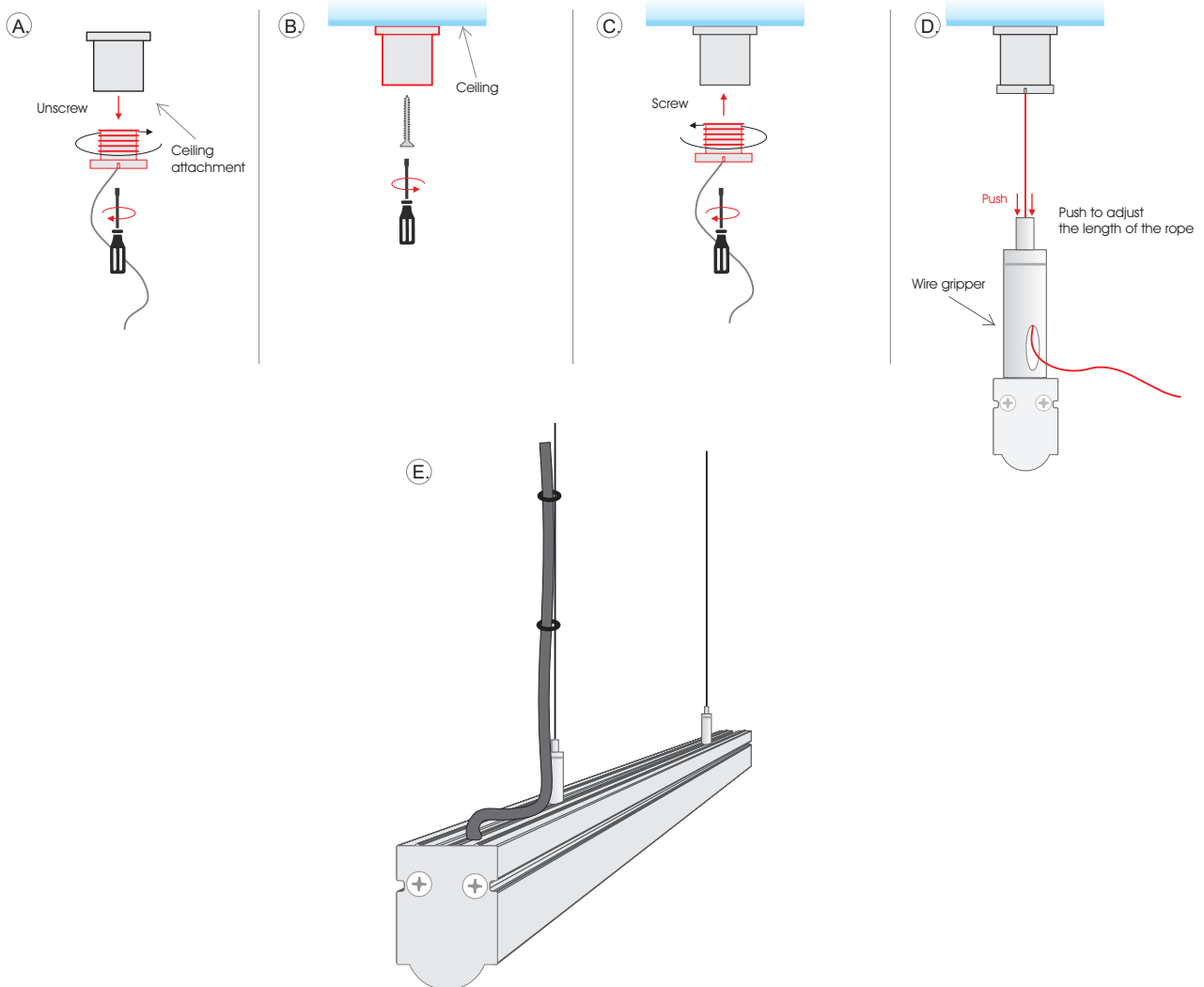

1 Cut the led strip at the desired length, only at the cutting marks.

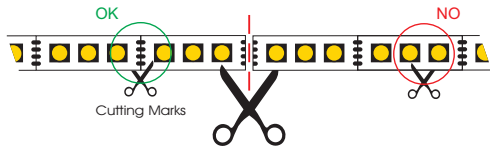

2 Insert the heat-shrinkable tubing, at the side of the led strip, where the cables will be soldered. Then, solder the cables on the led strip's pads.

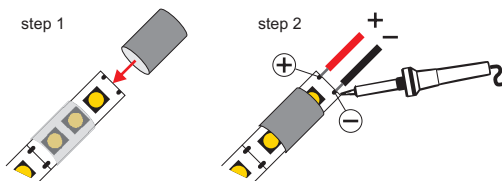

Attention

- Mind the polarity of the cables.
- The common cable is positive (+) for common anode led strips and negative (-) for common cathode led strips.
- The actual colors and the order of the cables, may be different.



3 Slide the heat-shrinkable tubing, to cover the soldered led strip's pads. Then, heat the heat-shrinkable tubing in order to shrink and wrap the led strip.

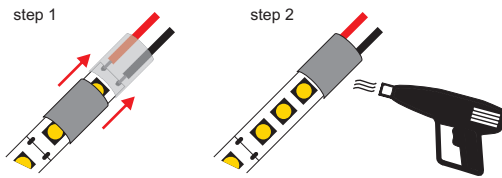

Attention

Do not cover the led, with the heat-shrinkable tubing.

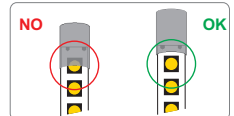

4 Remove gradually the masking tape and stick the led strip on the desired surface.



Attention

Avoid bending the led strip in any wrong way.

